

THIS DRAWING IS UNPUBLISHED. RELEASED FOR PUBLICATION 20
 © COPYRIGHT 20 BY TYCO ELECTRONICS CORPORATION. ALL RIGHTS RESERVED.

LOC	DIST	REVISIONS					
CE	00	P	LTR	DESCRIPTION	DATE	DWN	APVD
		U		REVISE PER 0A00-0601-04	10FEB05	KG	DK
		V		REVISE PER 0A00-0065-05	22FEB2005	BB	DK
		W		REVISE PER ECR-08-015882	19AUG2008	BB	DK

PART NUMBER	CONNECTOR TYPE	
503746-1	ST STYLE	
503746-2	FSMA	
503746-3	FC STYLE	SUPERSEDED BY 503746-7
503746-4	D4 TYPE	OBSOLETE
503746-5	AMP SC	SUPERSEDED BY 503746-7
503746-6	FSD	
503746-7	FC/SC	

- ① BLACK POLISHING BUSHING, ITEM 17, IS USED WITH STAINLESS STEEL AND CERAMIC FERRULES ONLY.
- ② BEIGE POLISHING BUSHING, ITEM 18, IS USED WITH POLYMER FERRULES ONLY.
- ③ DIE SET, ITEM 35, TO BE USED TO CRIMP ST, FSMA & D4 504XXX SERIES CONNECTORS ONLY.
- ④ AMP INSTRUCTION SHEETS AND MANUFACTURERS INSTRUCTION SHEETS.
- ⑤ OPTIONAL SHOULDER STRAP.

SUPERSEDED BY 503746-7
 OBSOLETE
 SUPERSEDED BY 503746-7

1	-	-	-	-	-	-	905111-7	LABEL, FC/SC	48
-	1	-	-	-	-	-	905111-6	LABEL, FSD	47
-	-	-	1	-	-	-	905111-4	LABEL, D4 TYPE	46
-	-	-	-	-	1	-	905111-2	LABEL, FSMA	45
-	-	-	-	-	-	1	905111-1	LABEL, ST STYLE	44
-	4	-	-	-	-	-	502023-1	ASSY FIXTURE KIT, FSD	43
1	-	-	-	-	-	-	492215-1	STRIP CARD, SC/FC POLY	42
1	-	-	-	-	-	-	1754636-1	STRIP CARD, FC/SC	41
-	-	-	1	-	-	-	492117-1	STRIP CARD, D4	40
-	1	-	-	-	-	-	503479-1	STRIP CARD, FSD, POLY	39
-	1	-	-	-	-	-	502241-1	STRIP CARD, FSD	38
-	-	-	-	-	1	-	501813-1	STRIP CARD, FSMA	37
-	-	-	-	-	-	1	502791-1	STRIP CARD, ST STYLE	36
-7	-6	-5	-4	-3	-2	-1	PART NUMBER	DESCRIPTION	ITEM NO

-	-	-	-	-	-	1	501814-1	STRIP CARD, ST STYLE	35
1	-	-	-	-	-	-	503910-1	FC/SC DIE SET	34
③	-	-	-	1	-	1	58552-1	HEX DIE SET	33
-	1	-	-	-	-	-	58510-1	FSD DIE ASSEMBLY	32
-	-	1	-	1	-	1	58424-1	DIE SET ASSEMBLY	31
1	-	-	-	-	-	-	58588-1	HAND TOOL FRAME (BLUE)	30
-	1	1	1	1	1	1	1976850-1	HAND TOOL FRAME (BLACK)	29
-	-	-	12	-	-	-	492119-1	CURING SLEEVE, D4	28
10	-	10	-	-	-	-	502656-1	CURING SLEEVE, AMP SC	27
12	-	-	-	12	-	-	502862-2	CURING SLEEVE, FC	26
-	-	-	-	-	3	-	502248-2	CURING SLEEVE, FSMA	25
-	-	-	-	-	-	3	502259-2	CURING SLEEVE, ST STYLE	24
10	-	-	10	10	-	10	501857-2	ALCOHOL WIPE	23
-	1	-	-	-	-	-	501791-1	POLISH BUSH, FSD	22
10	-	10	-	-	-	-	502631-1	POLISH BUSH, AMP SC	21
1	-	-	-	1	-	-	504862-1	POLISH BUSH, FC STYLE	20
-	-	-	1	-	-	-	504741-1	POLISH BUSH, D4 TYPE	19
-	-	-	-	-	1	-	228025-1	POLISH BUSH, FSMA	18
②	-	-	-	-	-	1	503304-2	POLISH BUSH, ST STYLE	17
①	-	-	-	-	-	1	503304-1	POLISH BUSH, ST STYLE	16
10	6	10	6	6	6	6	501473-3	EPOXY APPLICATOR	15
10	10	-	1	1	10	10	228433-7	POLISHING FILM, 1µm	14
5	-	-	-	-	-	-	502748-2	POLISHING FILM, FINAL	13
10	10	1	1	1	10	10	228433-5	POLISHING FILM, 0.3µm	12
10	10	1	1	1	10	10	228433-8	POLISHING FILM, 5µm	11
-	10	1	1	-	10	10	228433-9	POLISHING FILM, 15µm	10
3	-	3	3	3	-	3	501858-1	POLISHING PAD, GREEN	9
-	3	-	-	-	-	1	501523-1	POLISHING PAD, WHITE	8
1	1	1	1	1	1	1	501197-1	POLISHING PLATE	7
1	1	1	1	1	1	1	504064-1	SCRIBE TOOL	6
1	1	1	1	1	1	1	1278637-1	KEVLAR SHEARS	5
1	1	1	1	1	1	1	501205-1	WATER BOTTLE	4
1	1	1	1	1	1	1	504024-3	FIBER STRIPPER, .012	3
1	1	1	1	1	1	1	1754708-1	STRIP TOOL, COMBINATION	2
1	1	1	1	1	1	1	1278540-1	PREMIUM SOFTCASE	1
-7	-6	-5	-4	-3	-2	-1	PART NUMBER	DESCRIPTION	ITEM NO

THIS DRAWING IS A CONTROLLED DOCUMENT FOR TYCO ELECTRONICS CORPORATION IT IS SUBJECT TO CHANGE AND THE CONTROLLING ENGINEERING ORGANIZATION SHOULD BE CONTACTED FOR THE LATEST REVISION.		DWN P. YEAGER 09AUG94 CHK J. SABO 10AUG94 APVD K. MONROE 10AUG94	Tyco Electronics Harrisburg, PA 17105-3608
DIMENSIONS: mm 		TOLERANCES UNLESS OTHERWISE SPECIFIED: 0 PLC ± 1 PLC ± 2 PLC ± 3 PLC ± 4 PLC ± ANGLES ±	NAME TERMINATION KIT, OPTIMATE SIZE A2 CAGE CODE 00779 DRAWING NO 503746 RESTRICTED TO
MATERIAL -		PRODUCT SPEC -	SCALE 1:2 SHEET 1 OF 2 REV W
CUSTOMER DRAWING		APPLICATION SPEC -	
		WEIGHT -	

THIS DRAWING IS UNPUBLISHED. RELEASED FOR PUBLICATION 20
 © COPYRIGHT 20 BY TYCO ELECTRONICS CORPORATION. ALL RIGHTS RESERVED.

LOC	DIST	REVISIONS					
CE	00	P	LTR	DESCRIPTION	DATE	DWN	APVD
		-		SEE SHEET 1			

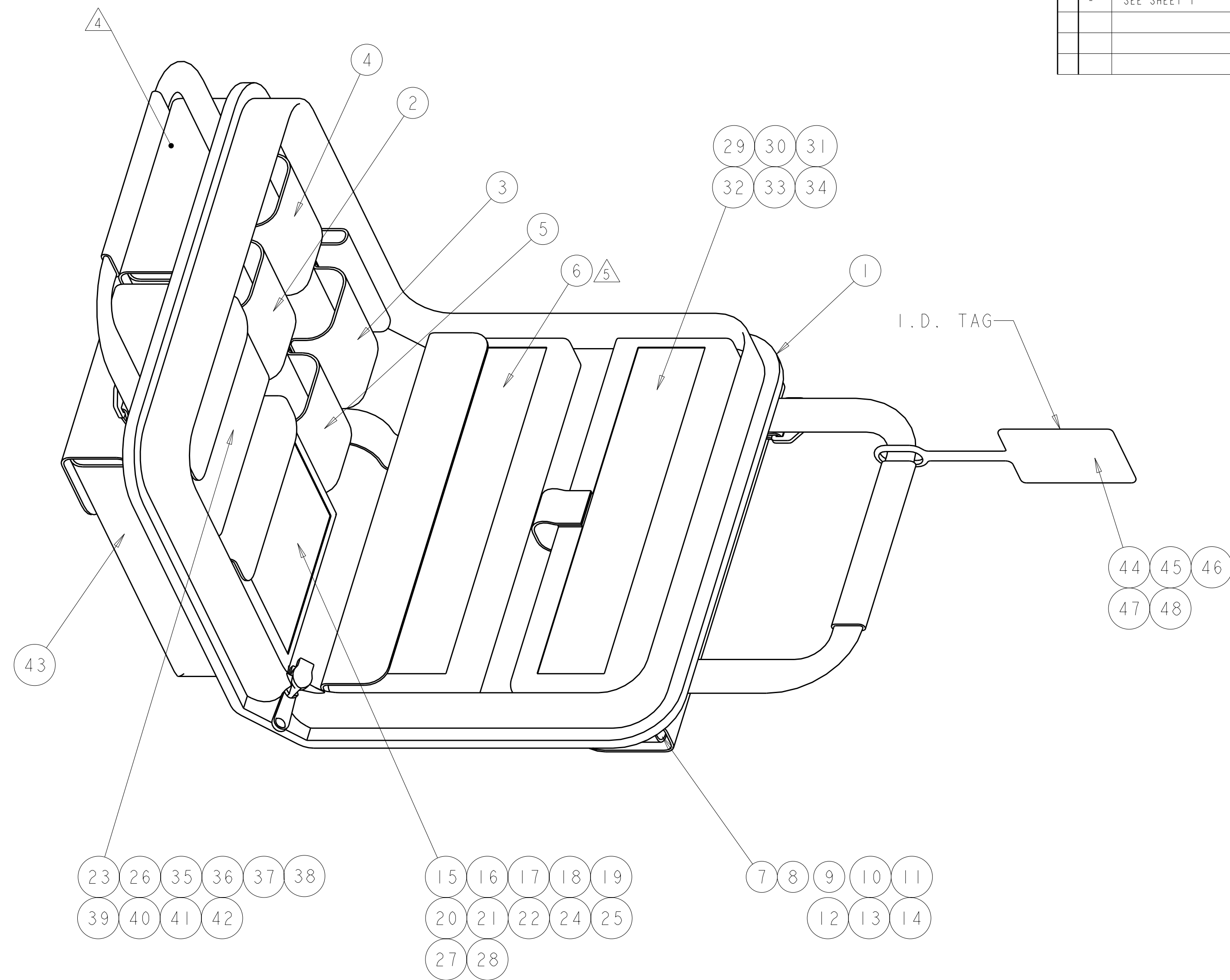

<small>THIS DRAWING IS A CONTROLLED DOCUMENT FOR TYCO ELECTRONICS CORPORATION. IT IS SUBJECT TO CHANGE AND THE CONTROLLING ENGINEERING ORGANIZATION SHOULD BE CONTACTED FOR THE LATEST REVISION.</small>		DWN P. YEAGER 09AUG94 CHK J. SABO 10AUG94 APVD K. MONROE 10AUG94	Tyco Electronics Tyco Electronics Harrisburg, PA 17105-3608
DIMENSIONS: mm 	TOLERANCES UNLESS OTHERWISE SPECIFIED: 0 PLC ± 1 PLC ± 2 PLC ± 3 PLC ± 4 PLC ± ANGLES ± FINISH -	PRODUCT SPEC - APPLICATION SPEC - WEIGHT -	NAME TERMINATION KIT, OPTIMATE SIZE A2 CAGE CODE 00779 DRAWING NO. C-503746 RESTRICTED TO -
MATERIAL -		CUSTOMER DRAWING	
		SCALE 1:2	SHEET 2 OF 2 REV W